



Model BW Series

Washdown Compact Bench Scale



The Ohaus BW Series Compact Bench Scale – Dependability, Durability, Ohaus Quality and Value.

The Ohaus BW Series Compact Bench Scale is a cost-effective portioning, packing and general weighing scale designed to provide fast and accurate weighing performance in dry and washdown environments. With an internal sealed rechargeable lead-acid battery, IP65 housing and high-speed display update, the Ohaus BW Series offers durability and dependability in an affordable design.

Standard Features Include:

- 4 popular capacity models: 1.5 kg x 0.2 g, 3 kg x 0.5 g, 6 kg x 1 g, 15 kg x 2 g
- Maximum displayed resolutions from 1:6000 - 7500
- Type approved resolution 1:3000
- Durable high-profile ABS housing with stainless steel pan (pan is dishwasher-safe)
- IP65 dust and water jet protection
- 4 adjustable rubber leveling feet with integral front-panel leveling indicator
- 1 red LED weight display: 6-digit, 7-segment, 14 mm high characters, adjustable brightness level
- Fast display \leq 2 seconds
- 4 raised tactile mechanical buttons: On/Off, Check, Tare, Zero
- 2 weighing units: kg or g
- AC or Internal Rechargeable lead-acid battery
- 50-hour internal rechargeable battery with power-saving Auto-shut off feature
- Voltage level indication
- Over-Under checkweighing function
- Industry leading support

The Ohaus BW Compact Bench Scale

Specifications

Model	BW1.5	BW3	BW6	BW15
Capacity x Readability	1.5 kg x 0.2 g	3 kg x 0.5 g	6 kg x 1 g	15 kg x 2 g
Maximum Displayed Resolution	1:7,500	1:6,000	1:6,000	1:7,500
Type Approval Resolution *	1:3,000			
Load Cell Capacity	3.5kg	6.5kg	15kg	30kg
Construction	ABS plastic housing with stainless steel pan			
Protection	IP65			
Pan Dimensions	230W x 180D mm			
Leveling Components	4 adjustable rubber feet with integral panel mounted level bubble indicator			
Display	1 red LED; 6-digit, 7-segment, 14H mm characters, adjustable brightness			
Weighing Units	kg, g			
Keyboard	4 raised tactile mechanical keys: [ON/OFF], [CHECK], [TARE], [ZERO]			
Calibration Weight	2/3 and Full Scale Capacity			
Over Range Capacity	Full Scale Capacity +9d			
Tare Range	Full Capacity by Subtraction			
Zero Range	Power-on: $\pm 10\%$ / Keyboard: $\pm 2\%$ Full Scale Capacity			
Stabilization Time	within 2 seconds			
Power	9VDC 500mA AC Adapter / 6V 5Ah rechargeable lead acid battery			
Battery Operation	50 hours continuous use with 15 hour recharge time			
Safe Overload	150% Full Scale Capacity			
Operating Temperature Range	-10°C to $+40^{\circ}\text{C}$, 10% to 95% humidity, non-condensing			
Storage Temperature Range	-25°C to $+50^{\circ}\text{C}$, 10% to 95% humidity, non-condensing			
Scale Dimensions	230W x 310D x 127H mm			
Shipping Dimensions	295W x 381D x 190H mm			
Scale Unit Weight	4.4 kg			
Shipping Weight	5.7 kg			

* OIML 3000e: R76/1992-NL 1-03.49

Alternate Views



BW Series - Rear View



BW Series - Bottom View



BW Series - Large Pan Accessory

Outline Dimensional Drawings

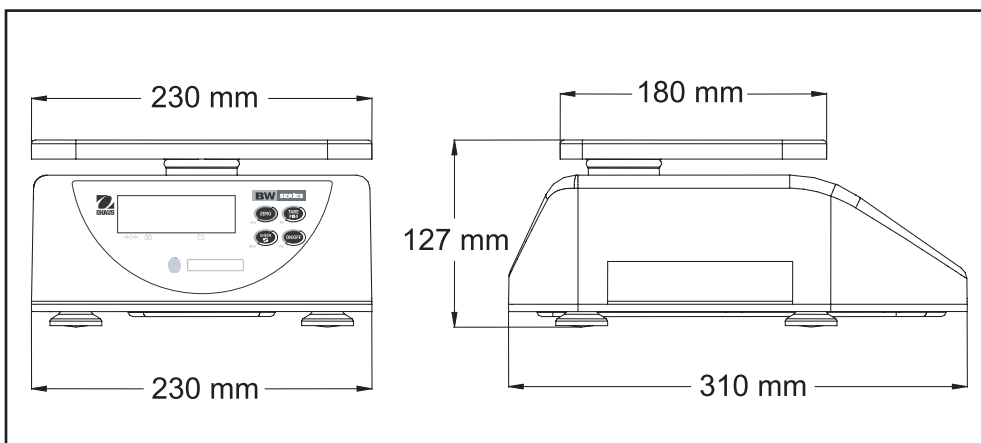

www.ohaus.com

With offices throughout Europe,
Asia, and Latin America

*ISO 9001:2000
Registered Quality Management System

80774221 © Copyright Ohaus Corporation

